

Thank You for purchasing this quality product. Be sure to check all packing material carefully for small parts, which may have come loose inside the carton during shipment. Identify and count all parts and compare with the parts lists below. Please be sure to read the Notes section at the bottom of the page before beginning assembly. Thank You

ASSEMBLY INSTRUCTION

SIDE CHAIR

MODEL : SM007 (C-1623-RTA)

SIZE : 18-1/8" x 22-1/2" x 38-3/4" H

List of Part For 1 Set

Code	Figure	Part	Qty.
01		Chair Back	1
02		Seat	1
03		Front Leg	2
04		Side Stretcher	2

List of hardware For 1 Set

Code	Figure	Hardware	Qty.
a		Hex. Bolt M6 x 80mm	4
b		Hex. Bolt M6 x 60mm	4
c		Hex. Bolt M6 x 40mm	2
d		Flat Washer 1/4" x 18mm	10
e		Spring Washer 1/4"	10
f		Spanner	1
g		CSKRS Screw #8 x 1 1/2"	4

Important Notes

- * Keep all hardware parts out of reach of children.
- * Must tighten screws periodically. With use screws will become loose. Check tightness of all screws every 6-8 weeks.
- * Don't attempt to repair or modify parts that are broken or defective. Please contact the store immediately.
- * Do not tighten all screw / bolt until all completely assembled.

Notes

- * Place all wooden parts on a clean and smooth surface such as a rug or carpet to avoid the parts from being scratched.
- * Check to be sure that you have all parts and hardware.
- * Remove all wrapping materials including staples & packing straps before you start to assemble.

Care And Maintenance

- * The Touch of a soft cloth is all the maintenance your wood pieces will ever need.
- * Never use harsh chemicals or abrasive cleaner as they could mark or destroy finish.

MADE IN MALAYSIA

Step 1

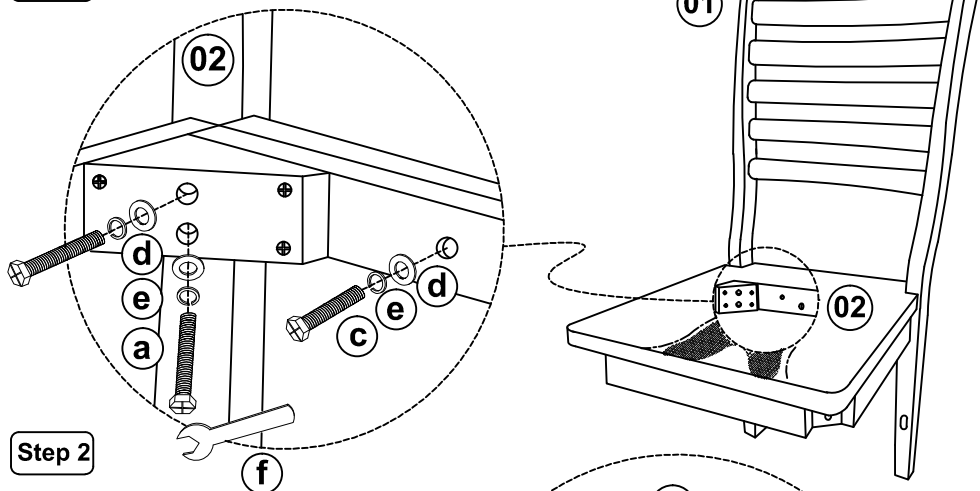

Step 2

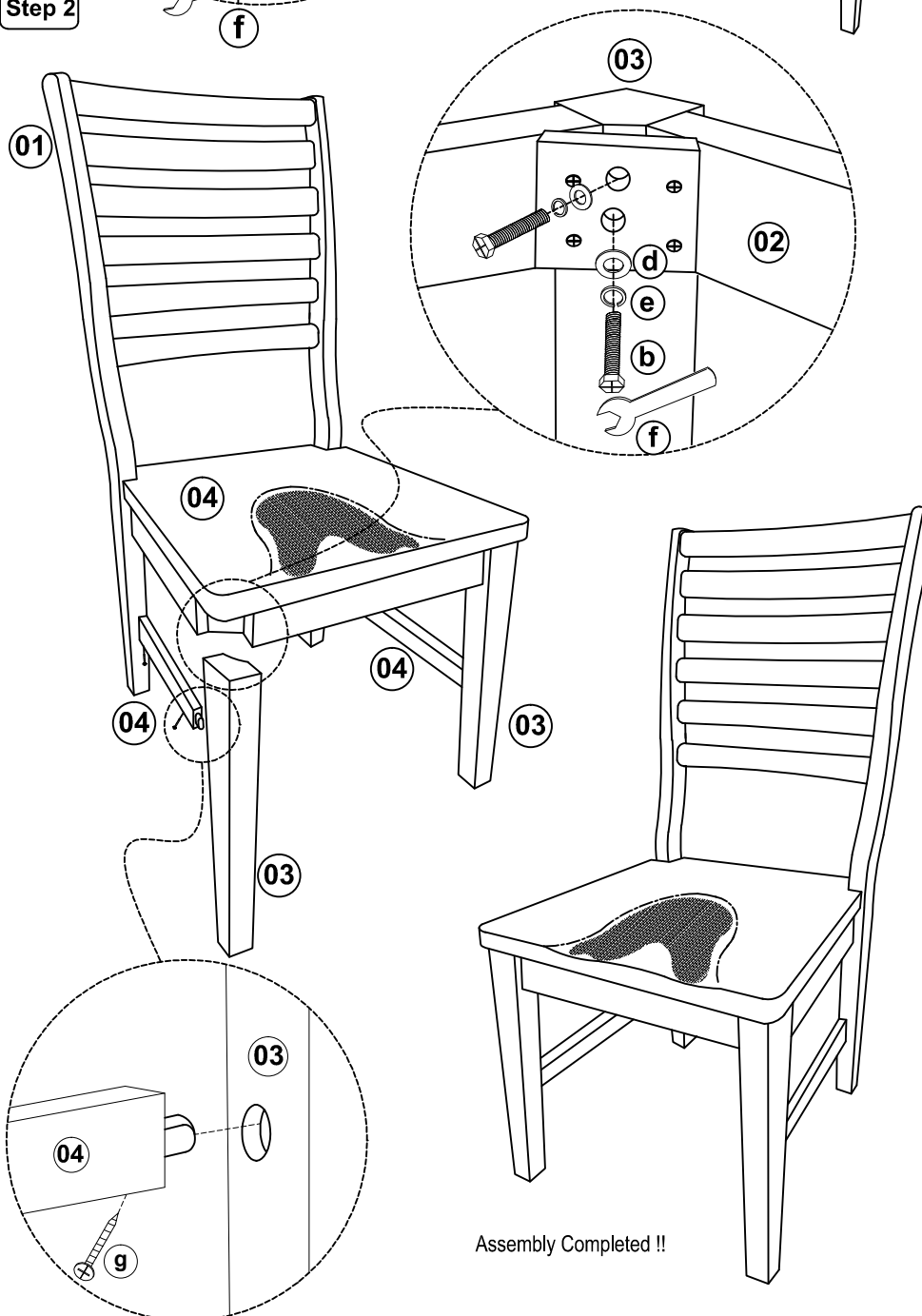

Assembly Completed !!